

- Aluminum Diaphragm
- Rubber Surround
- Ferrite Magnet
- Copper Cap
- Enhanced Voice Coil Cooling

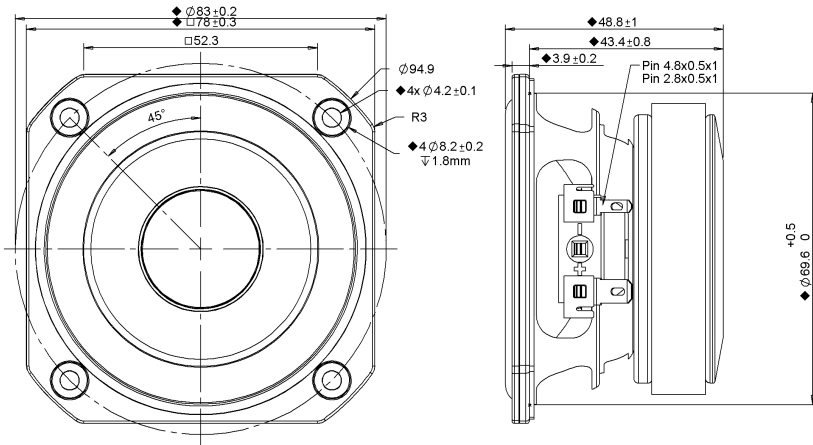

SPECIFICATIONS

Transducer Size	3	in	
Impedance	8	Ω	
Frequency Range ¹	60 - 16000	Hz	
Sensitivity ² (2.83V 1W @ 1m)	83.7 83.7	dB	
Power Rating (IEC 268-5)	25	W	
Voice Coil Size	25.7	mm	
Air Gap Winding Height	$H_{ag} H_{vc}$	4 8.1	mm
Net Weight	0.38	kg	

PARAMETERS ³

Eff. Piston Area	S_d	28.9	cm^2
DC Resistance	R_e	6.3	Ω
Minimum Impedance	Z_{min}	6.8	Ω
Inductance	L_e	0.092	mH
Resonance Frequency ⁴	F_s	100	Hz
Mechanical Q Factor	Q_{ms}	6.71	-
Electrical Q Factor	Q_{es}	0.836	-
Total Q Factor	Q_{ts}	0.74	-
Moving Mass	M_{ms}	2.64	g
Compliance	C_{ms}	910	$\mu\text{m}/\text{N}$
Equivalent Volume	V_{as}	1.08	L
Motor Force Factor	Bl	3.58	Tm
Motor Efficiency	β	2.04	$(Bl)^2 / R_e$
Linear Excursion ⁵	X_{max}	3.38	mm
Max Mechanical Excursion ⁶	X_{mech}	-	mm

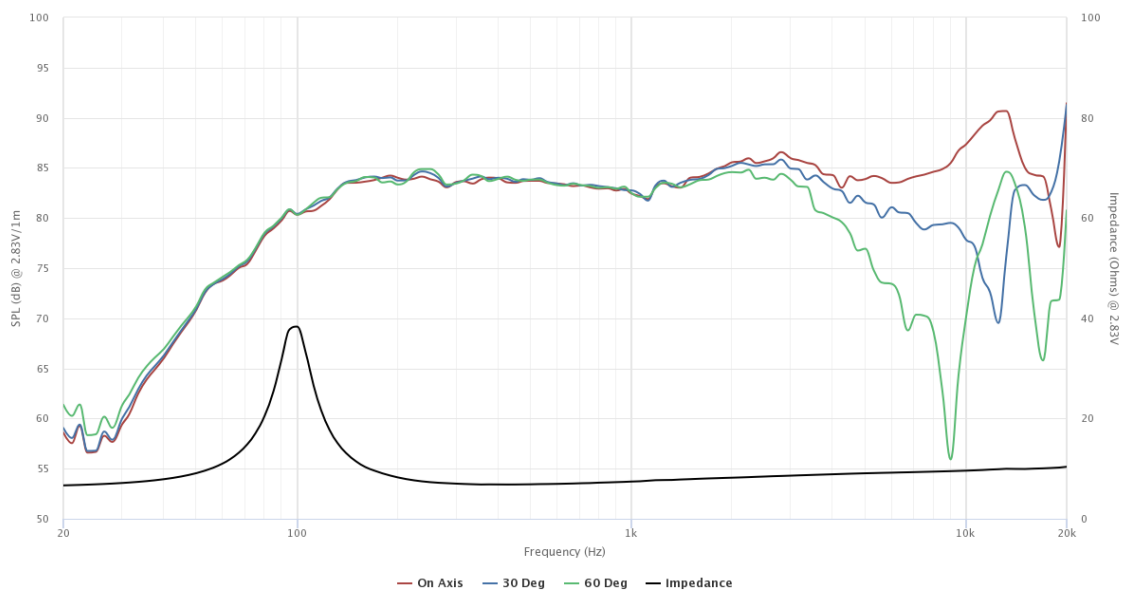

Details on this spec sheet are for reference only and should not be used for setting production limits. Specifications and product cosmetics are subject to change without notice. Peerless is a registered trademark of Tympany Enterprises. All measurements conducted in test lab at $25^\circ\text{C} \pm 10^\circ\text{C}$, 50%RH $\pm 10\%$. ¹ Specified by Engineering as linear working range of transducer. ² Measured at 2.83V at 1m and normalized to 1W with respect to nominal impedance. ³ Measured in Free Air without preconditioning, therefore subject to some deviation. ⁴ Impedance and F_s value measured under different conditions. ⁵ Equal/Overhung: $(H_{vc} - H_{ag})/2 + H_{ag}/3$. Underhung: $(H_{ag} - H_{vc})/2 + H_{vc}/3$. ⁶ Mechanically limited excursion (e.g. bottoming, spider crash).